

You get a set of plans that call for trusses to be supported by a compression ring, what to do next? This document will walk you through the steps to properly design the trusses.

The information that follows is based on what we typically have seen specified on plans provided to the fabricator. All assumptions stated here must be verified with what is called out on the plans, and if there is any discrepancy, the fabricator is to confirm the parameters to be used with the building designer prior to the design or fabrication of the components. It is strongly recommended that trusses not be built until the sealing engineer has reviewed the connection details and finished the truss component design. Also note that all diagrams are for reference only.

The first step is inputting your full span truss. You will need to add a flat top and bottom chord equivalent to the compression ring diameter. These members will be defined as webs and labeled as “part 2” in VersaTruss. Running them as webs ensures that those joints are pinned.

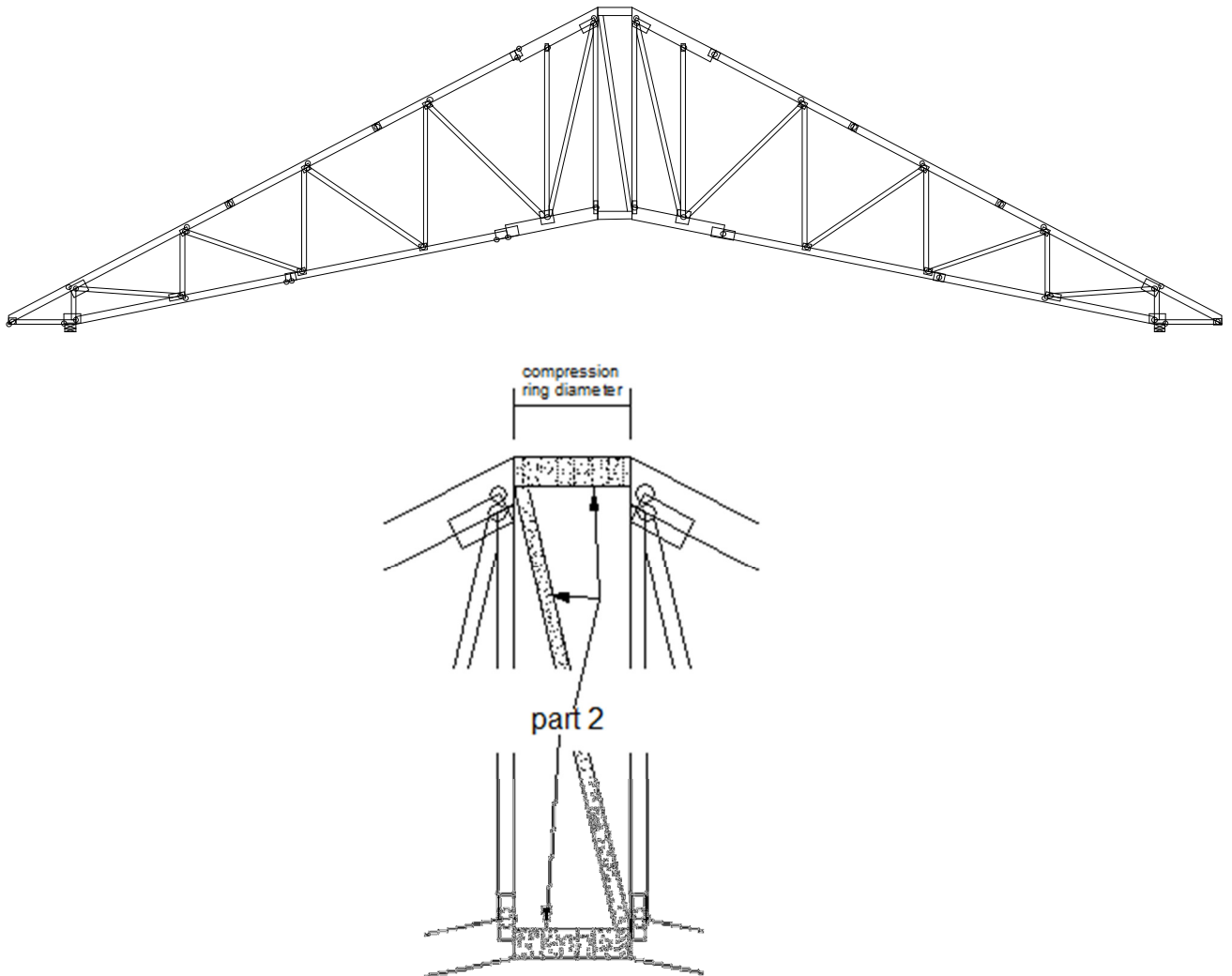

Figure 1

The truss should then be loaded according to the tributary area with trapezoidal load as required/needed and then analyzed. When you have a design that works, the forces given for the horizontal top and bottom chord members (that were entered as webs) will determine what magnitude of horizontal force the connections for the compression ring will need to be capable of withstanding. The vertical component of the web force in the diagonal will determine what the magnitude of the vertical shear connection will need to be.

One other consideration in the truss design is the connection made along the lower portion of the truss. Many times the attachment will be achieved using a tension collar. If this connection wraps around the end vertical at the lower joint, the diagonal web should be run to the top chord (as shown in the Figure 1) to allow room for the tension collar to wrap around the inside edge of the end verticals. Additional plating checks must be made at these joints by the reviewing engineer due to the use of this tension collar.

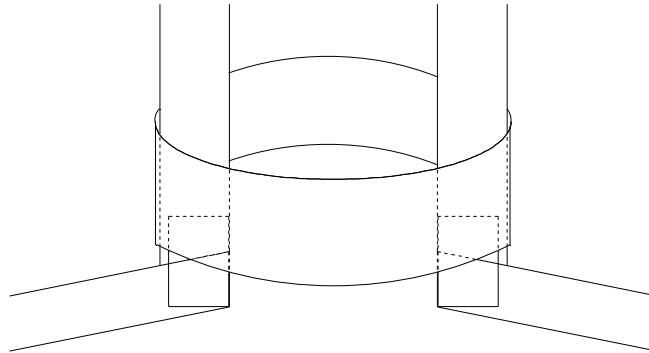

Figure 2

There will be rare instances when the roof system will have a steel tension ring around the perimeter of the building. In this case your truss may be run as a pinned-pinned design. This must be verified with the building designer.

This is a general overview of a compression ring truss design. As with any special designs, there are scenarios which are not covered here, and additional considerations may be required when designing the trusses.

For additional information, or if you have questions, please contact the MiTek Engineering department.